

# Instrucțiuni de montaj

## Receptor Attika Jumbo din PUR



Grumbach

Art.Nr.3436 Receptor Attika Jumbo

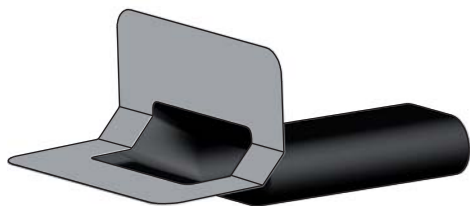

### Exemplu de montaj:

Receptor Attika Jumbo montat în acoperiș cald.

Creați decuparea în atic.

$d = 280\text{mm}$   
 $h = 150\text{mm}$   
 $H = \text{Grosime izolație plus } 70\text{mm}$

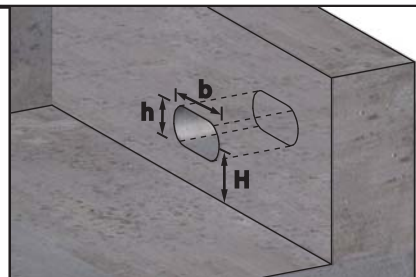

1. Se montează bariera de vapori.

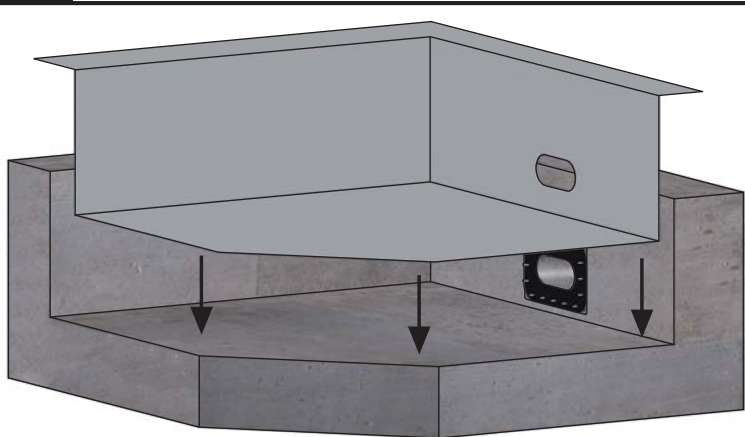

2. Se montează conectorul special Grumbach la bariera de vapori (a se vedea instrucțiunile de instalare separate).

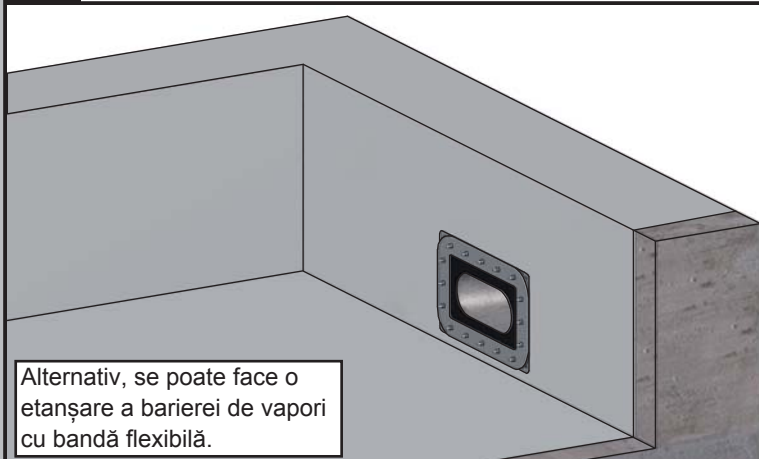

Alternativ, se poate face o etanșare a barierei de vapori cu bandă flexibilă.

3. Se montează izolarea acoperișului și a aticului.

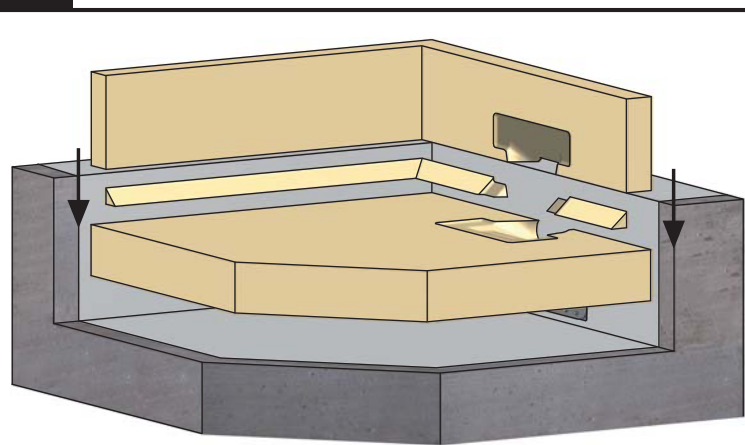

4. Se montează receptorul Attika Jumbo în atic prin conectorul deja montat.

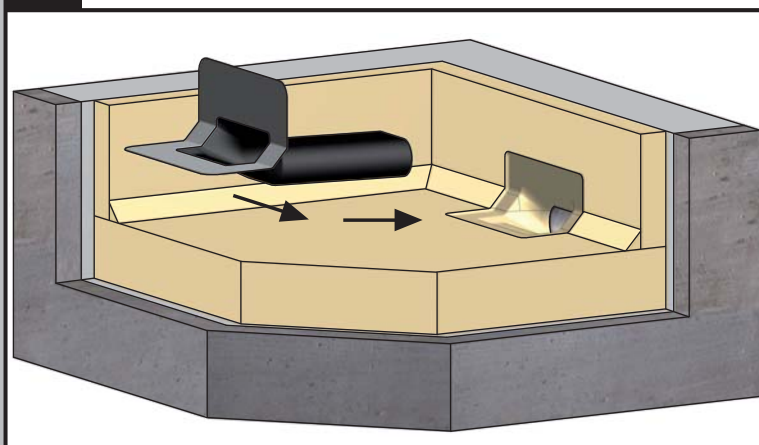

5. Se montează membrana de hidroizolație cu decuparea în jurul gurii de scurgere a receptorului. Se lipește, apoi de manșonul receptorului.

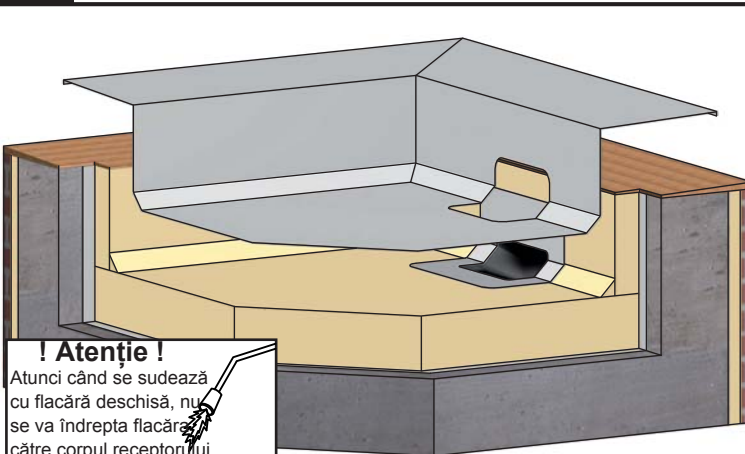

### ! Atenție !

Atunci când se sudează cu flacăra deschisă, nu se va îndrepta flacăra către corpul receptorului.

6. Dacă este necesar, se montează parafrunzarul, folosind kitul de montaj inclus.

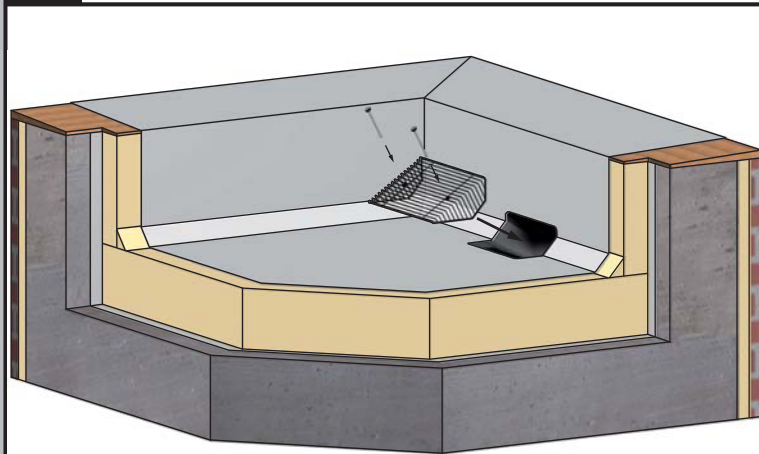

# Instrucțiuni de montaj

## Receptor Attika Jumbo din PUR



**7.** Racordare adaptor DN150  
Art. nr. . 439

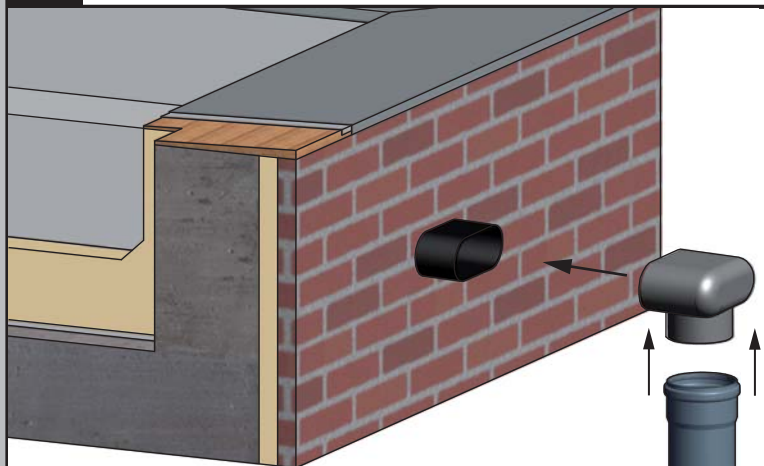

**8.** Racordare la colectorul de apă  
Art. Nr. 3438/2438.

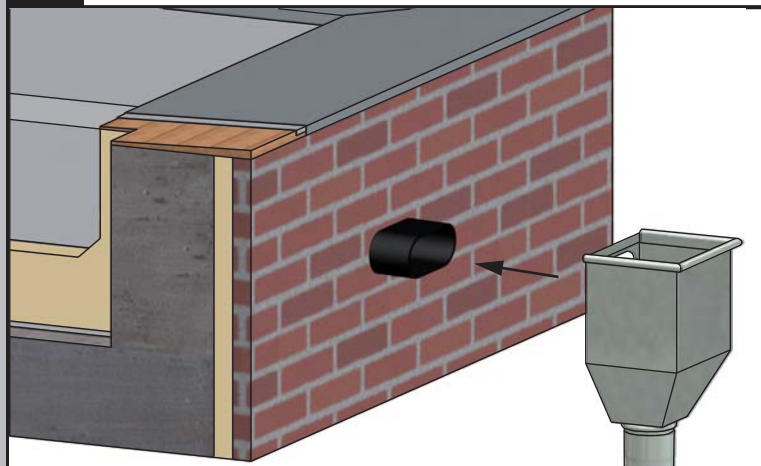

**9.** Scurgere liberă.

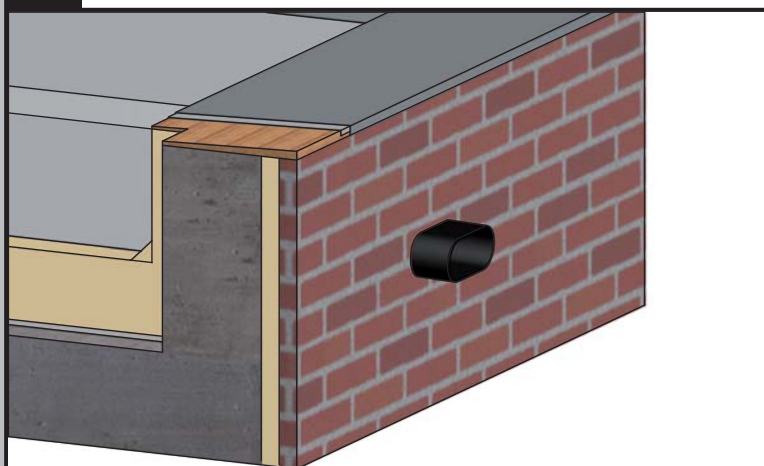

**10.** Atunci când este utilizat ca preaplin de urgență se folosește accesoriul special Grumbach Art.Nr. 5917.

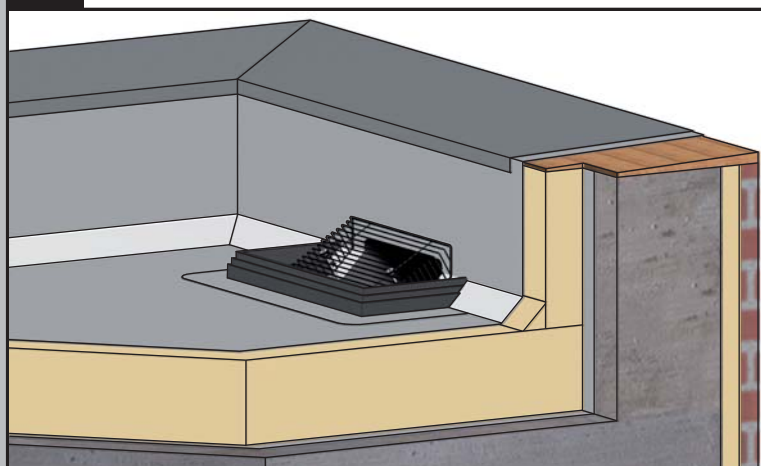

### Date tehnice:

